

In our effort to provide quick and simple solutions, we've designed three different, standard cobot bases.

While simple in design, all three bases offer enough space and versatility for most common cobot applications.

These bases are stock items and are available for immediate shipping.

These bases are available to be shipped in kit form or completely assembled.

Please contact us for pricing.

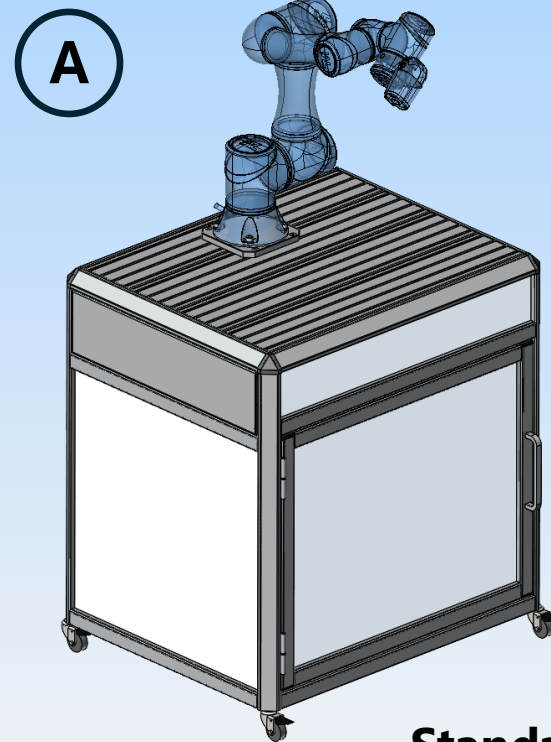

Standard

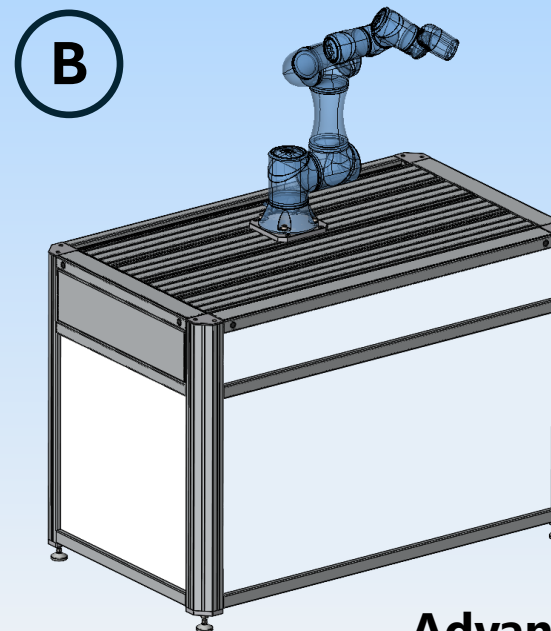

Advanced

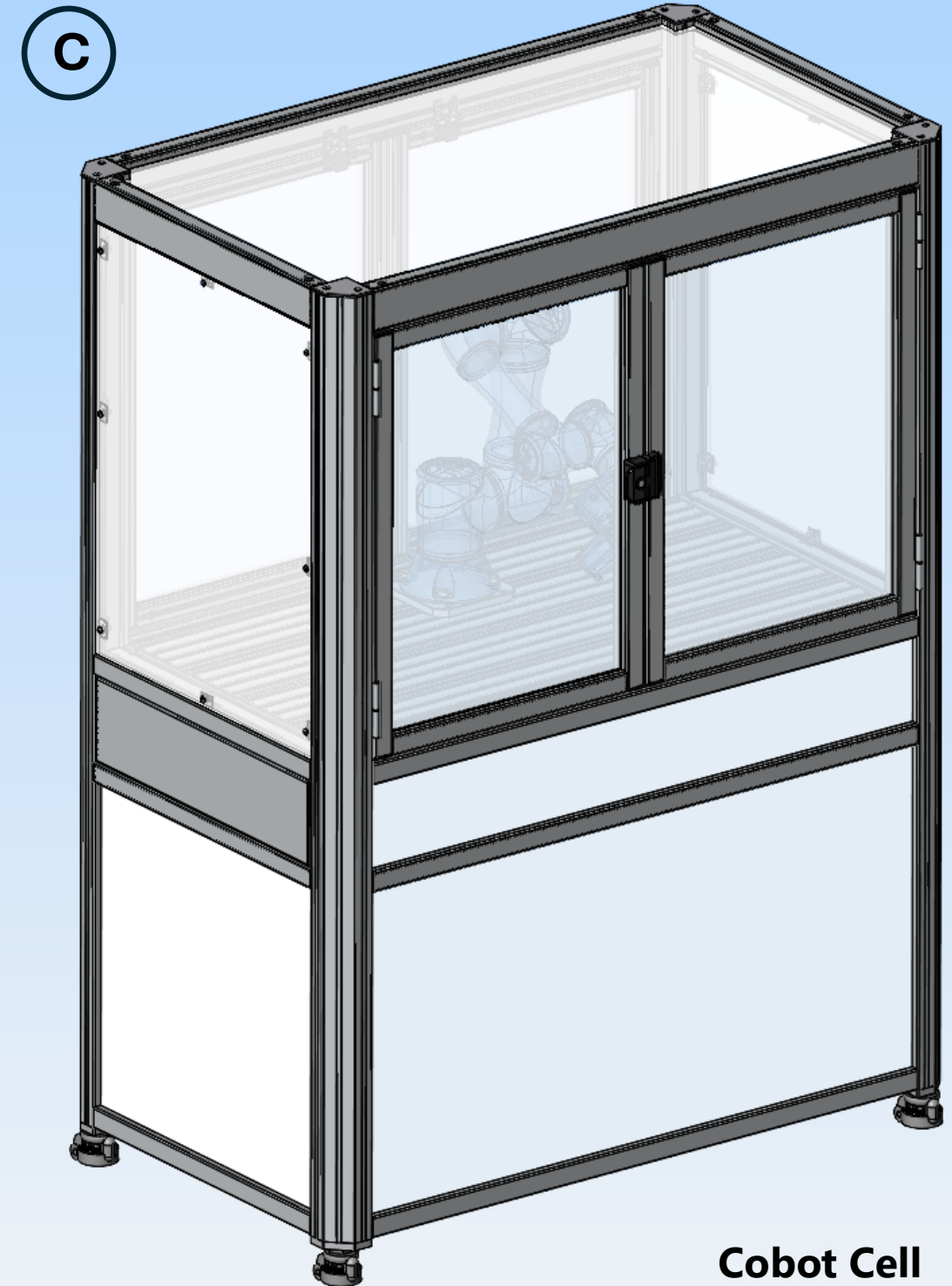

Cobot Cell



A) 75.71.0001 Cobot Station - Standard

(Cobot MT5-700 integrated)

Dimensions:

W- 890 mm (35")

D- 720 mm (28.35")

H- 970 mm (38.19")

Drawer:

W- 530 mm (20.86")

D- 450 mm (17.71")

Stroke: 500mm (19.68")

Weight:

65 kg (143.3lbs)

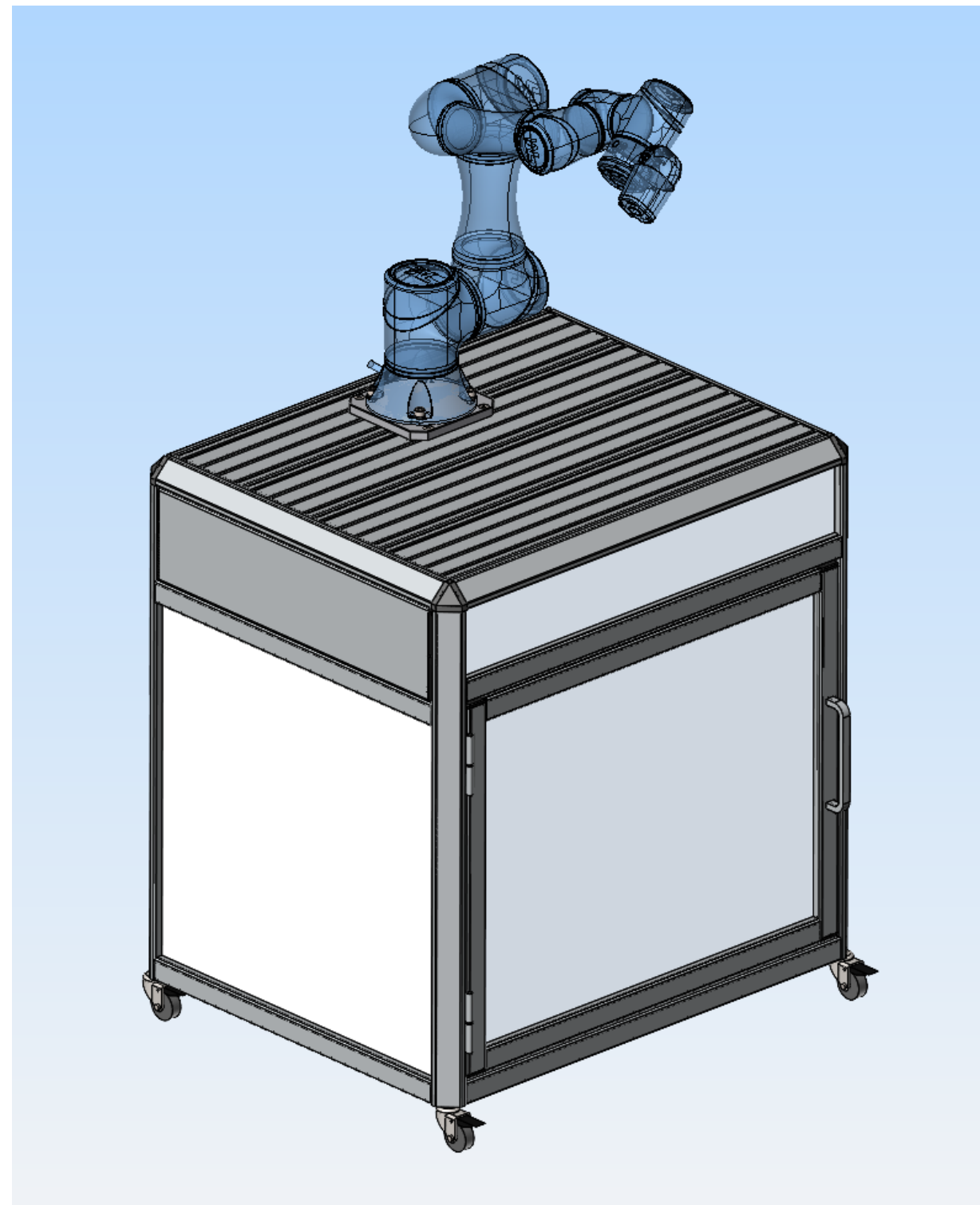

Our cobot station is a mobile solution that provides the extra benefit of an integrated drawer that can accommodate all necessary controls, accessories and tools for your cobot model.

This base includes the options of having adjustable leveling feet or casters.

This cobot station is made from MayTec profiles from our PG40 and can be individually adapted to your custom solutions.

Delivery options:

Kit form ready for assembly

Completely assembled



A) 75.71.0001 Cobot Station - Standard

Shown here with an open drawer.

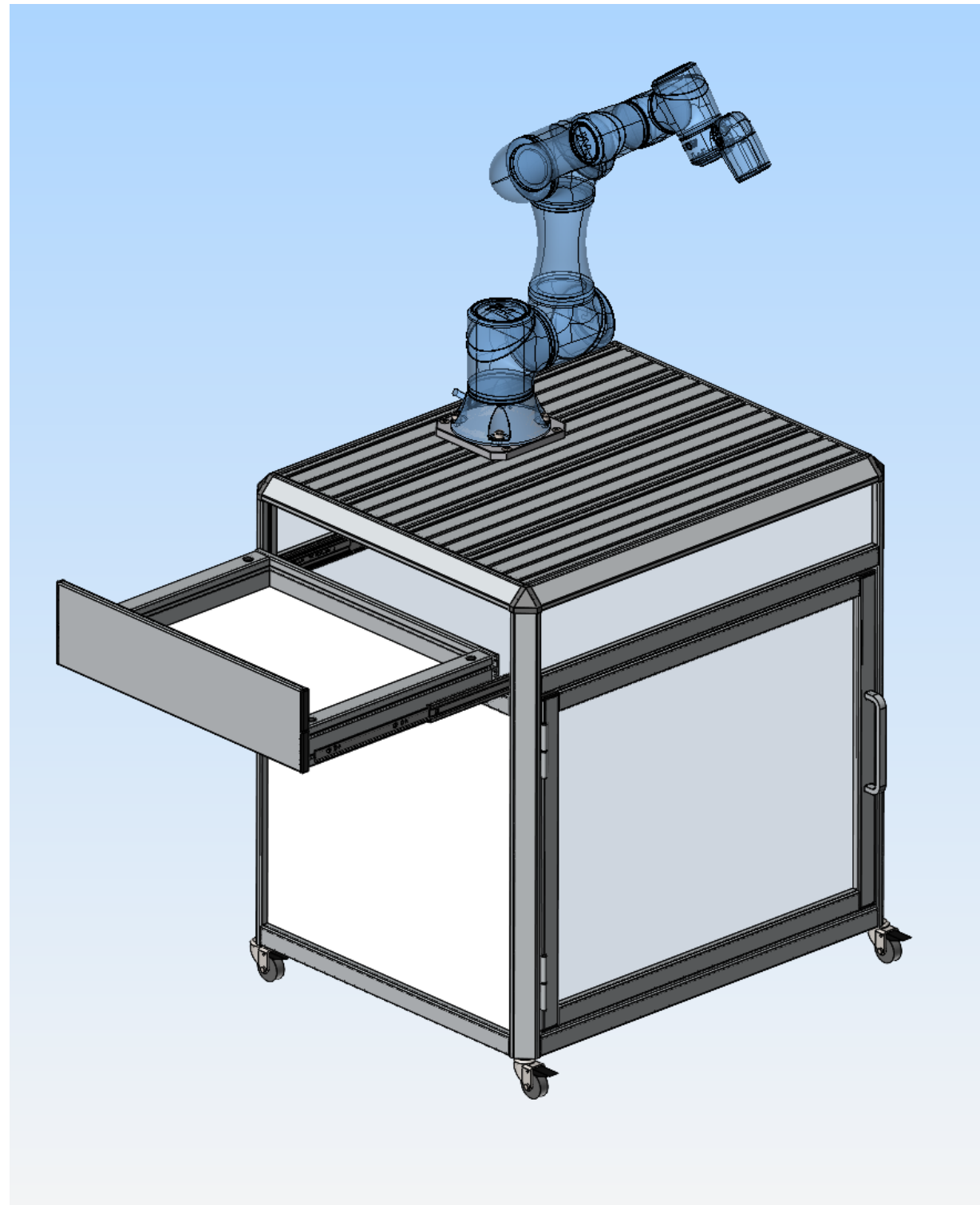

B) 75.72.0001 Cobot Station - Advanced

(Cobot MT5-700 integrated)

Dimensions:

W- 1360 mm (53.54")

D- 800 mm (31.50")

H- 970 mm (38.19")

Drawer:

W- 530 mm (20.86")

D- 450 mm (17.71")

Stroke: 500mm (19.68")

Weight:

105 kg (231.48lbs)

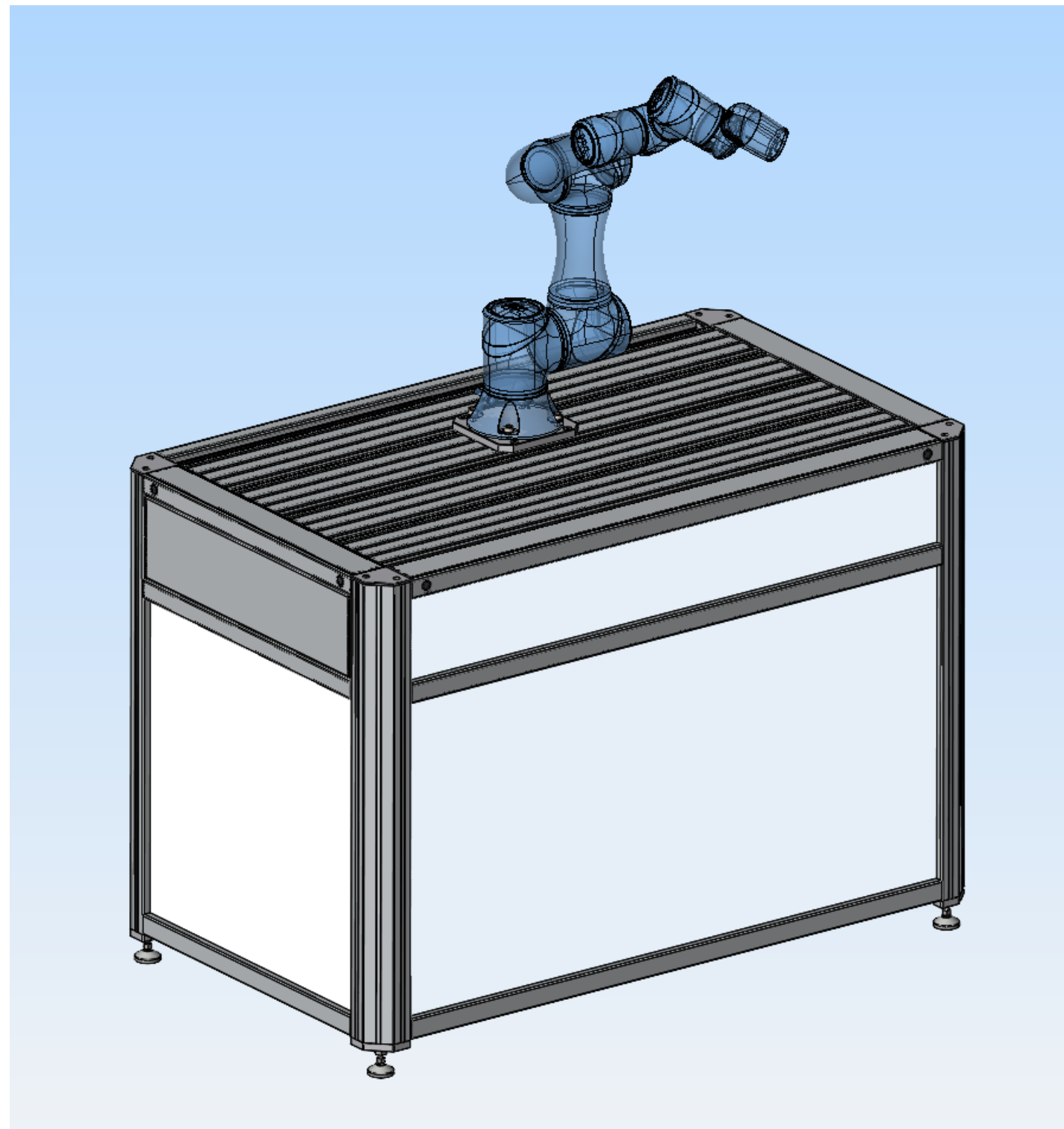

This cobot workstation has been specially designed for the use of more advanced applications.

Thanks to its generous base cabinet and a drawer, it offers more than enough space to accommodate all necessary controls, accessories, and tools of your cobot model.

This base includes the options of having adjustable leveling feet or casters.

This cobot station is made from MayTec profiles from our PG40 and can be individually adapted to your custom solutions.

Delivery options:

Kit form ready for assembly

Completely assembled



B) 75.72.0001 Cobot Station - Advanced

Shown here with an open drawer.

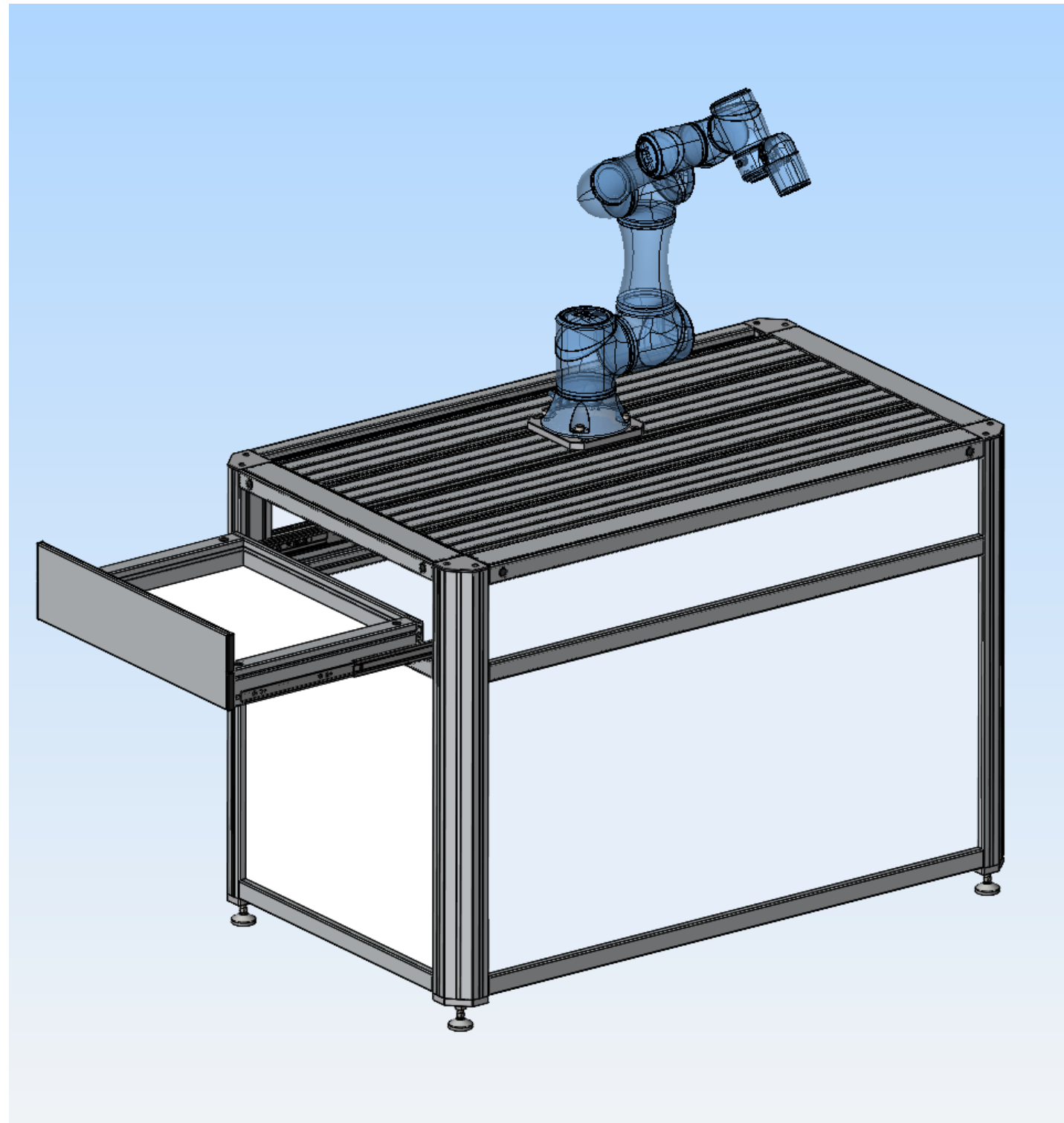

C) 75.73.0001 Cobot Cell

(Cobot MT5-700 integrated)

Dimensions:

W- 1360 mm (53.54")

D- 800 mm (31.50")

H- 1900 mm (74.80")

Drawer:

W- 530 mm (20.86")

D- 450 mm (17.71")

Stroke: 500mm (19.68")

Weight:

180 kg (396.83lbs)



This cobot cell is designed to be used in complex applications while providing maximum protection for the operators and machine.

Thanks to its generous base cabinet and a drawer, it offers more than enough space to accommodate all necessary controls, accessories, and tools of your cobot model.

This cobot cell base includes the options of having adjustable leveling feet or casters.

This cobot cell is made from MayTec profiles from our PG40 and can be individually adapted to your custom solutions.

Delivery options:

Kit form ready for assembly

Completely assembled



C) 75.73.0001 Cobot Cell

Shown here with an open drawer.



C) 75.73.0001 Cobot Cell

Backside view

